

K12 SYSTEM L 164 Drop down

With standard sprung hinges. Opening with handle.

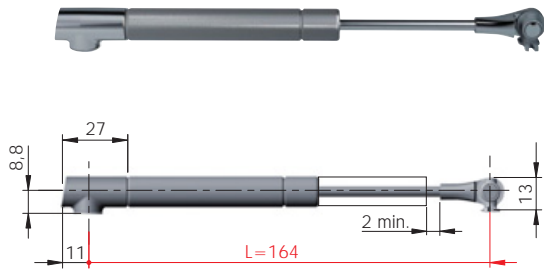

ZAnk EP ST

= 100 pcs.

48050200UZ

0

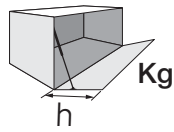

Rev. 01

h	Door weight (Kg)										
	1	2	3	4	5	6	7	8	9	10	11
200	1 x K12	2 x K12		3 x K12			4 x K12				
250	1 x K12	2 x K12		3 x K12		4 x K12					
300	1 x K12	2 x K12		3 x K12		4 x K12					

These are experimental results to be checked by the customer. **In accordance with the actual European regulation, we suggest to use at least two stays for each door.** Our technical department is at your disposal to test further cases out of this chart.

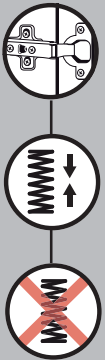

BRACKETS Ø15:

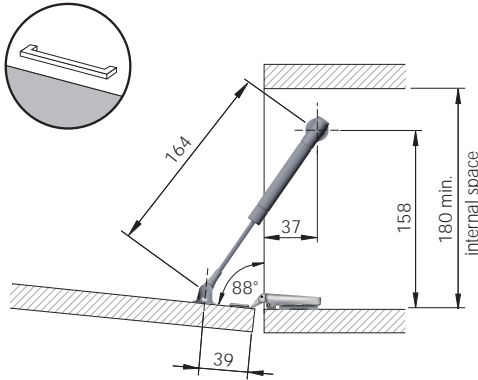

SCREW FIXING BRACKETS:

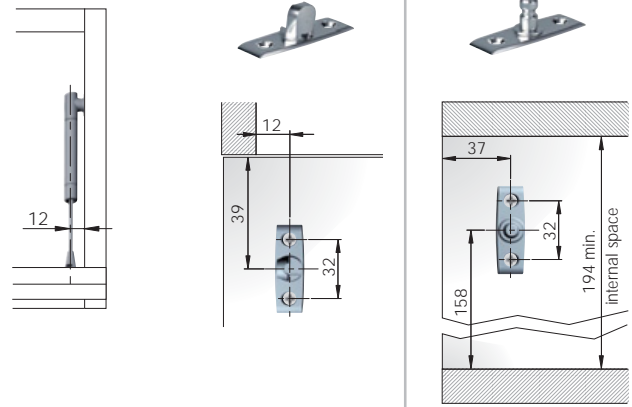

The dimensions of the drilling plan refer to carcasses which use **standard sprung hinges** and mounting plates 0 mm. Please note that the opening angle shown data is purely indicative. It varies with respect to the hinge brand and adjustment carried out.

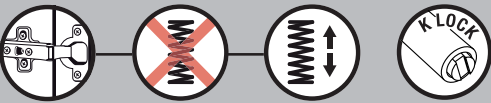

Please note that in case of use of **unsprung or negative hinges**, **magnet K Lock** is required. For details refer to section "PUSH CATCHES & MAGNETIC CATCHES".